



# HAES TIMER/PULSING RELAY UNIT



## DESCRIPTION

Double pole relay unit which is configurable to provide a variety of operational functions via DIL switch settings. The unit can be supplied from 17 to 30v dc and triggered via a switch -ve input or alternatively activated by a 24v signal such as a sounder circuit.

Available as a boxed unit c/w isolate key switch or PCB only with self adhesive, Nylon mounting pillars.

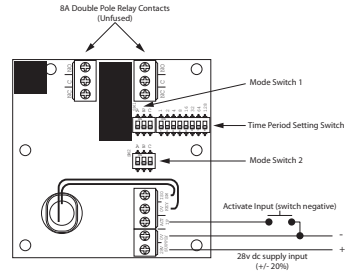
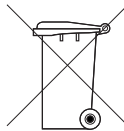

## OPERATION

Delay Mode	Following a trigger input the relay will activate after the set time delay.
Pulse Mode	Following a trigger input the relay will pulse alternately 'ON' and 'OFF'.
Disablement	When key is switched to Isolate position the activation of the relay is prevented.
On Delay	Delay time before the relay is switched 'ON'
Off Delay	Relay is activated immediately and then delay time before relay is switched 'OFF'.
Timed Disablement	Relay can be disabled for a predetermined time, up to 255 hours.
Buzzer Function	The buzzer ticks during a time delay running period, changes to a constant tone when the relay is activated and has slow intermittent beeps when the relay is disabled. (Buzzer can be switched off).
LED Indications	Yellow constant = relay disabled, yellow pulsing = timed disablement, red constant = relay operated, red pulsing = input active timer running.
Trigger Signal (a)	Provide constant supply voltage (17-30vdc) and activate timer via a switch -ve signal (from clean contacts or open collector outputs), necessary for disablement options.
Trigger Signal (b)	A 24v signal (can be a polarity reversed signal such as a fire alarm sounder circuit). With this option link the ACT IP to 0v. <i>Note:</i> With this option no power is available to the unit until the circuit is active and so the indicator & buzzer will not function until power is applied.



## PRODUCT CODES

BRTIMER	Boxed timer/pulsing relay
RECARD-TMR	PCB only c/w Nylon mounting pillars

# HAES TIMER/PULSING RELAY UNIT



Mode Switch 1



SWITCH	OFF 	ON 
<b>A</b>	<b>SECONDS</b> Delay/pulsing time = seconds.	<b>MINUTES</b> Delay/pulsing time = minutes.
<b>B</b>	<b>N/A</b>	<b>HOURS</b> Delay/pulsing time = hours (if this switch is set to ON, Switch A settings will be ignored).
<b>C</b>	<b>RELAY CONTINUOUS</b> Contacts will change over when trigger signal received, after set delay time.	<b>RELAY PULSING</b> Contacts of the relay will pulse when trigger signal received. In this mode the ON and OFF timings of the relay are controlled separately by bits 1-4 (ON) and 5-8 (OFF) of the time period setting switch. See details below. (This is most sensibly used when the timer is in 'SECONDS' mode).

Mode Switch 2



SWITCH	OFF 	ON 
<b>A</b>	<b>RELAY ON DELAY</b> The relay will operate after the set delay time. If 'PULSE' mode set using switch C on Mode Switch 1, the relay will pulse ON and then OFF in sequence.	<b>RELAY OFF DELAY</b> The relay will operate immediately when a trigger signal is received and will switch OFF after the set delay time. If 'PULSE' mode set using switch C on Mode Switch 1, the relay will pulse OFF and then ON in sequence.
<b>B</b>	<b>CONSTANT DISABLEMENT</b> If the Isolate key switch is operated the trigger signal will be ignored and the time delay will not start until the key switch is turned off.	<b>TIMED DISABLEMENT</b> If the Isolate key switch is operated briefly (for 1 second) the relay will be disabled for the set delay time. The input trigger will be ignored whilst the disablement is active.
<b>C</b>	<b>BUZZER ACTIVE</b>	<b>BUZZER INACTIVE</b>

Delay Time Period Setting Switch 3

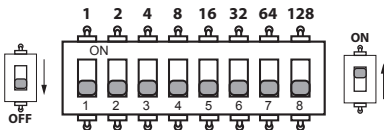

The delay time is set using DIL switch 3. Switches 1 - 8 on this DIL switch have the binary values 1 - 128 as per drawing above.

To set the delay time, switch the appropriate switches to the ON position. I.e. to set the value 10 set switches 2 and 4 to the ON position (binary values  $2 + 8 = 10$ ). Use Mode Switch 1 switches A & B as per above to select whether the value is SECONDS, MINUTES or HOURS.

Pulsing Time Period Setting Switch 3

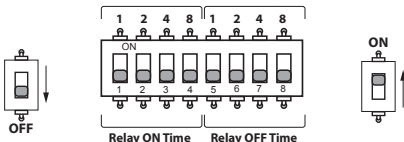

The delay time is set using DIL switch 3. Switches 1 - 8 on this DIL switch have the binary values 1 - 128 as per drawing above.

If the relay has been set to Pulsing using Mode Switch 1, switch C, the ON and OFF timings of the relay are controlled separately by bits 1-4 (ON) and 5-8 (OFF) of the time period setting switch using binary values 1 - 8 for a maximum value of 15. Mode Switch 1 switches A & B can be used to select whether the value is SECONDS, MINUTES or HOURS, however this is most sensibly used when the timer is in 'SECONDS' mode. **Note:- Pulse Mode With Timed Disablement (Switch 2 B ON):** The pulse rate is fixed to 1 second ON/OFF intervals and the delay time setting applies only.